

SLAM200

手持激光雷达扫描仪

LASER SCANNER

202501

快速使用指南

Quick Start Guide

(中文/English)

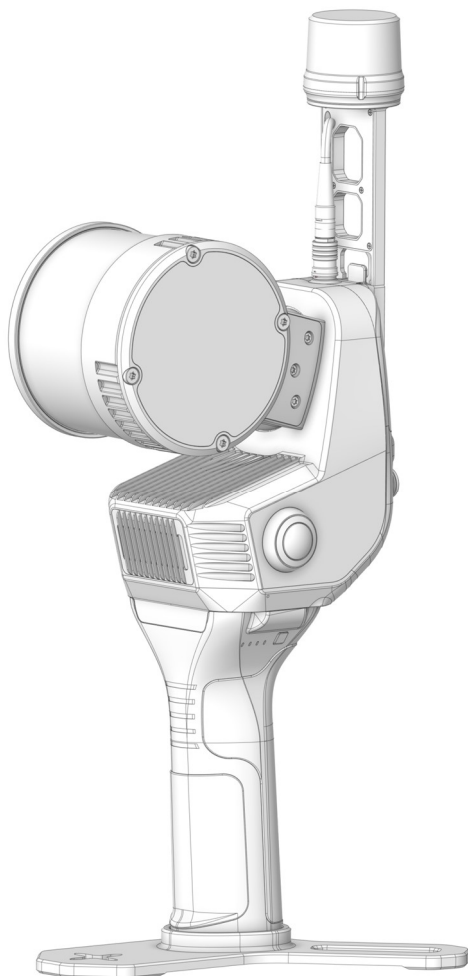

深圳飞马机器人股份有限公司

Shenzhen Feima Robotics Co., Ltd.

(中文)	2
提示说明	2
产品概述	3
部件说明	3
SLAM200 使用流程	6
设备组装	7
设备回收	12
指示灯说明	14
电池充电	16
数据存储	17
产品激活	18
外业数据采集	18
(English)	21
Notice	21
Product Overview	23
Part Introduction	24
SLAM200 Operating Process	27
Device Assembly	28
Equipment Recovery	33
Indicator Introduction	35
Battery Charging	37
Data Storage	38
Device Activation	39
Data Collection	39
FCC Warning	43

(中文)

提示说明

本文为《SLAM200 快速使用指南》，关于此设备更详细说明请详见《SLAM200 产品手册》。

提示：——特别提醒的重要内容

注意！——如操作错误有可能造成设备损坏的重要内容

 警告——如操作错误有可能造成设备损坏甚至人身伤害的重要内容

警告

- 作业人员在获取数据时应时刻注意周围环境，避免因注意力分散导致的安全事故；
- SLAM200 不具备防爆属性，严禁在加油站附近或瓦斯、天然气、甲烷、等易燃易爆气体聚集的矿井、坑道、化粪池等危险场景使用；
- 避免火灾、物权损失和人身伤害，使用电池、充电以及存储过程务必按照该手册指引操作。

注意！

- SLAM200 为高精度控制装置，摔落或受到外力碰撞可能会使 SLAM200 损坏，导致工作异常；
- 确保 SLAM200 电源开启后，云台转动不受外力阻挡；
- SLAM200 连电脑拷贝数据结束后，请先“安全弹出硬件”再断开 USB 电缆；
- 当需要关闭 SLAM200 设备时，请通过开关键关机，切勿在开机状态下直接移除电池手柄或断开电源（USB-PD 供电等）；
- 使用 SLAM200 的过程中请注意防尘防沙；
- 使用 SLAM200 时请注意保护设备两侧凸起的相机镜头避免被硬物刮花；
- 防溅、抗水、防尘功能并非永久有效，防护性能可能会因正常磨损而下降。浸液损坏不在保修保障范围内；
- 为了防止浸液损坏，请避免以下操作：
 - ① 将 SLAM200 置于高压或高流速的水中或故意将 SLAM200 浸入水中；
 - ② 使 SLAM200 跌落到地上或受到其他撞击；
 - ③ 拆解 SLAM200，包括拧下螺丝。

产品概述

SLAM200 是飞马机器人精心研发的第三代高精度手持三维激光雷达扫描仪。该扫描仪集成 32 线高性能激光传感器、搭载两颗 1200 万像素的全景相机、内置高精度 GNSS 模块以及更高性能的处理单元，为用户带来空间数据获取的全新体验。

SLAM200 配套 SLAM GO APP 和 SLAM GO POST Pro 后处理软件，其自研 SLAM 建图算法及赋色算法获得重大升级，实现实时彩色点云生成，不仅在建图精度与作业效率方面得到显著提升，更可让用户轻松获得高密度、超精细且色彩丰富的三维点云成果。

作为前两代产品的升级之作，SLAM200 不仅完美继承了前作的卓越性能，更在精度、细节捕捉、赋色效果和操作便捷性上实现了质的飞跃。SLAM200 卓越的性能与创新的设计，使其成为测量领域的新标杆，引领空间数据采集技术的未来发展。

部件说明

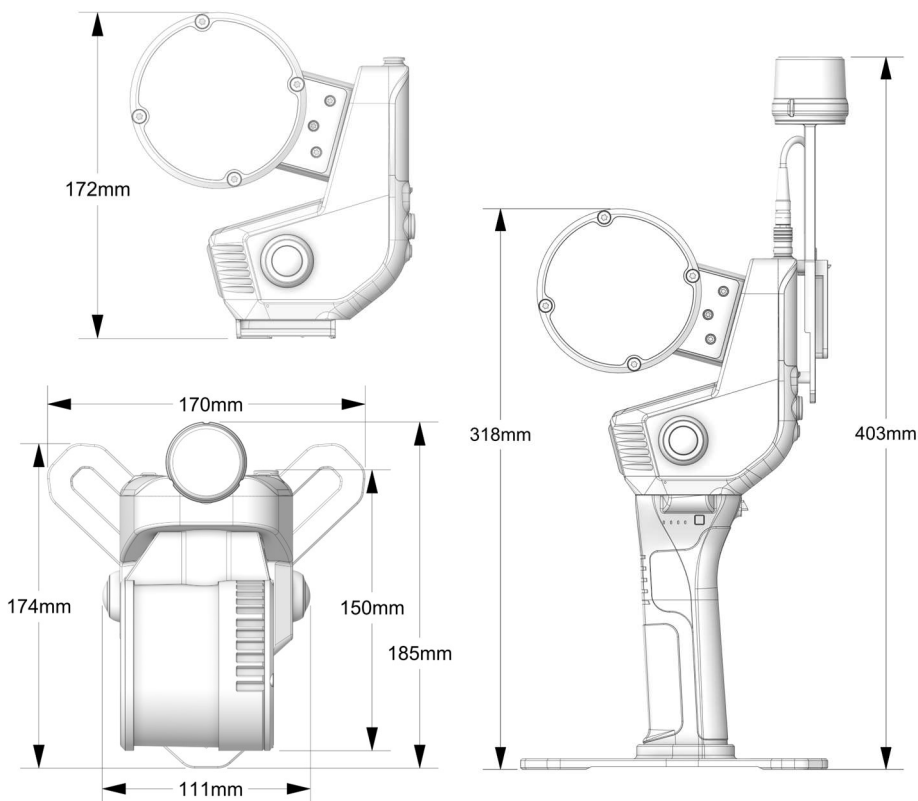

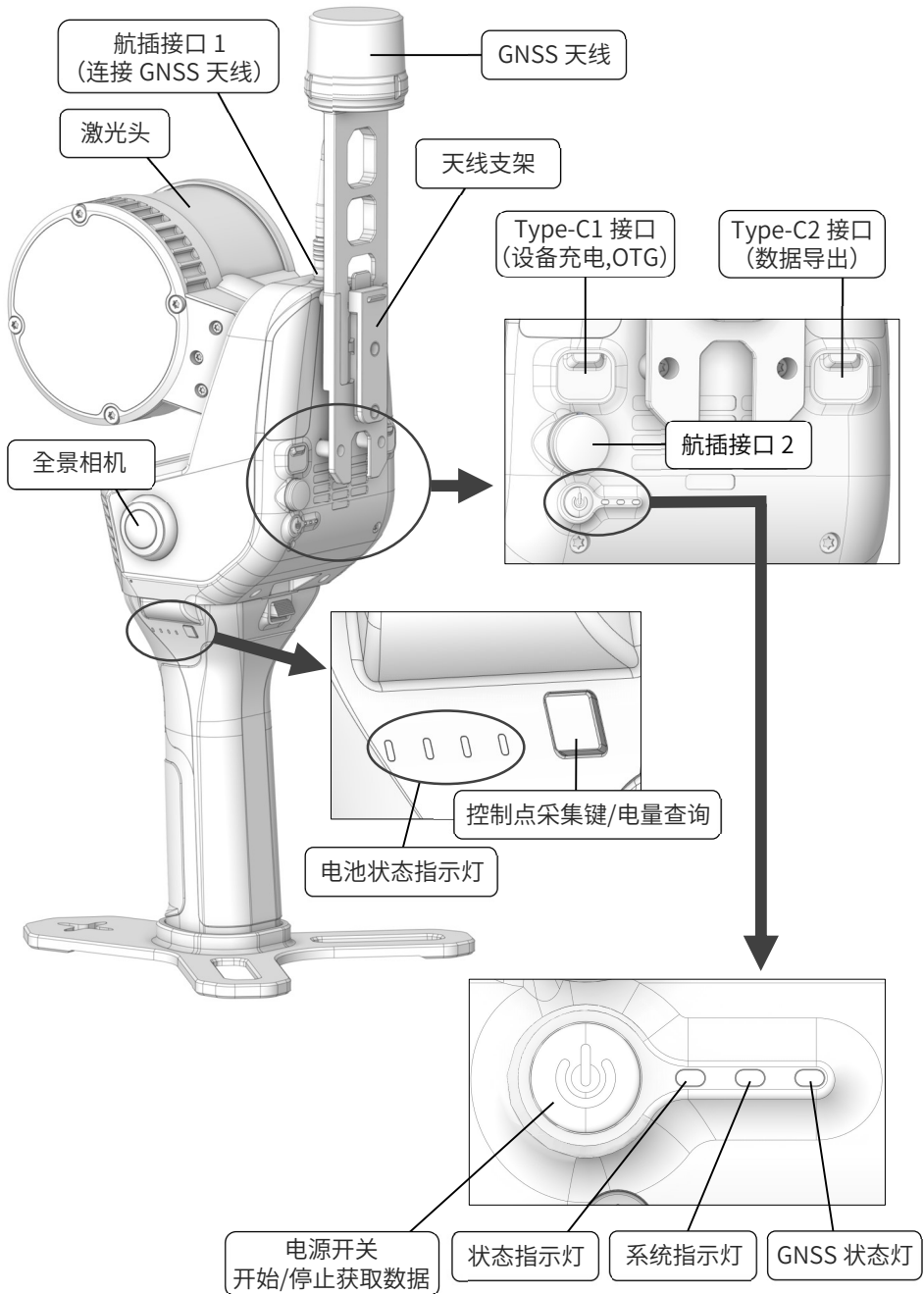



SLAM200 使用流程



设备组装

1 安装底座



② 安装手柄

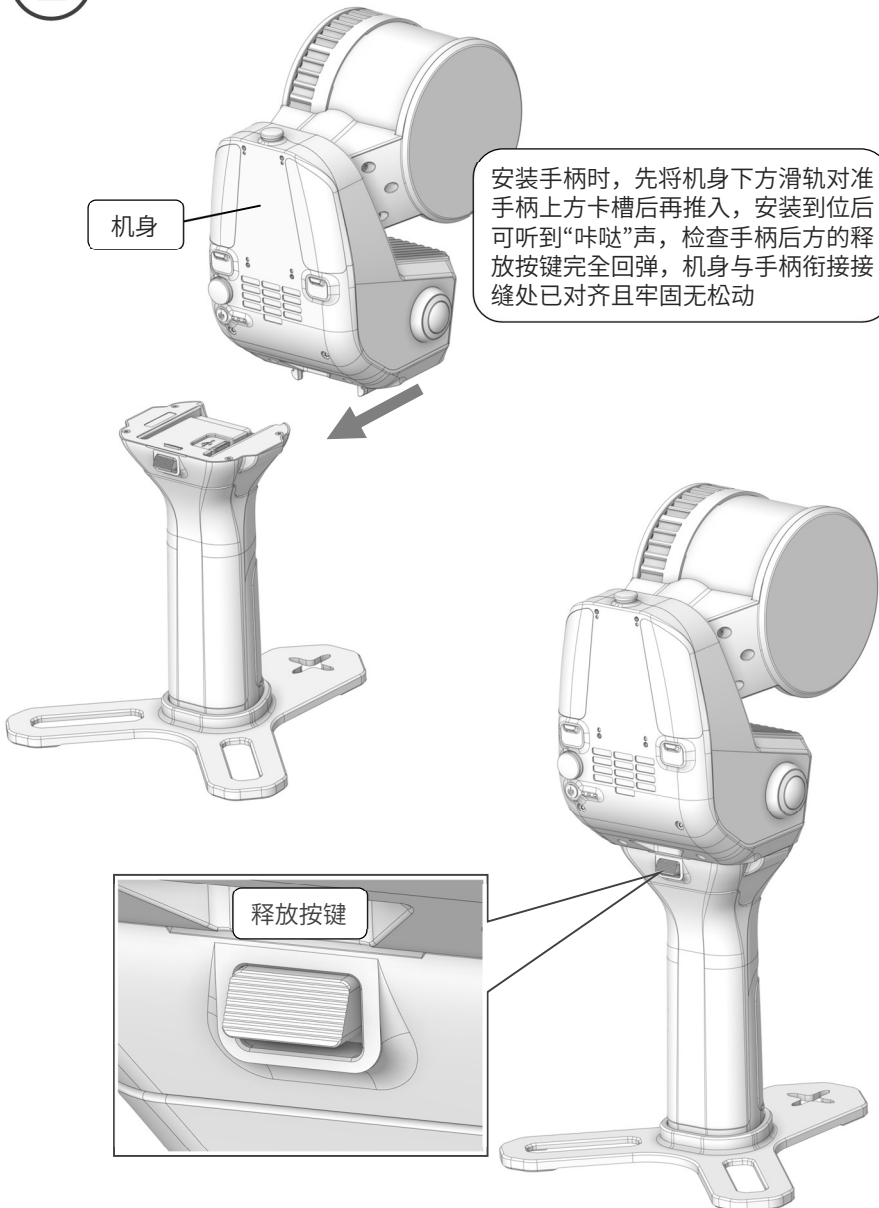

3 安装 GNSS 天线

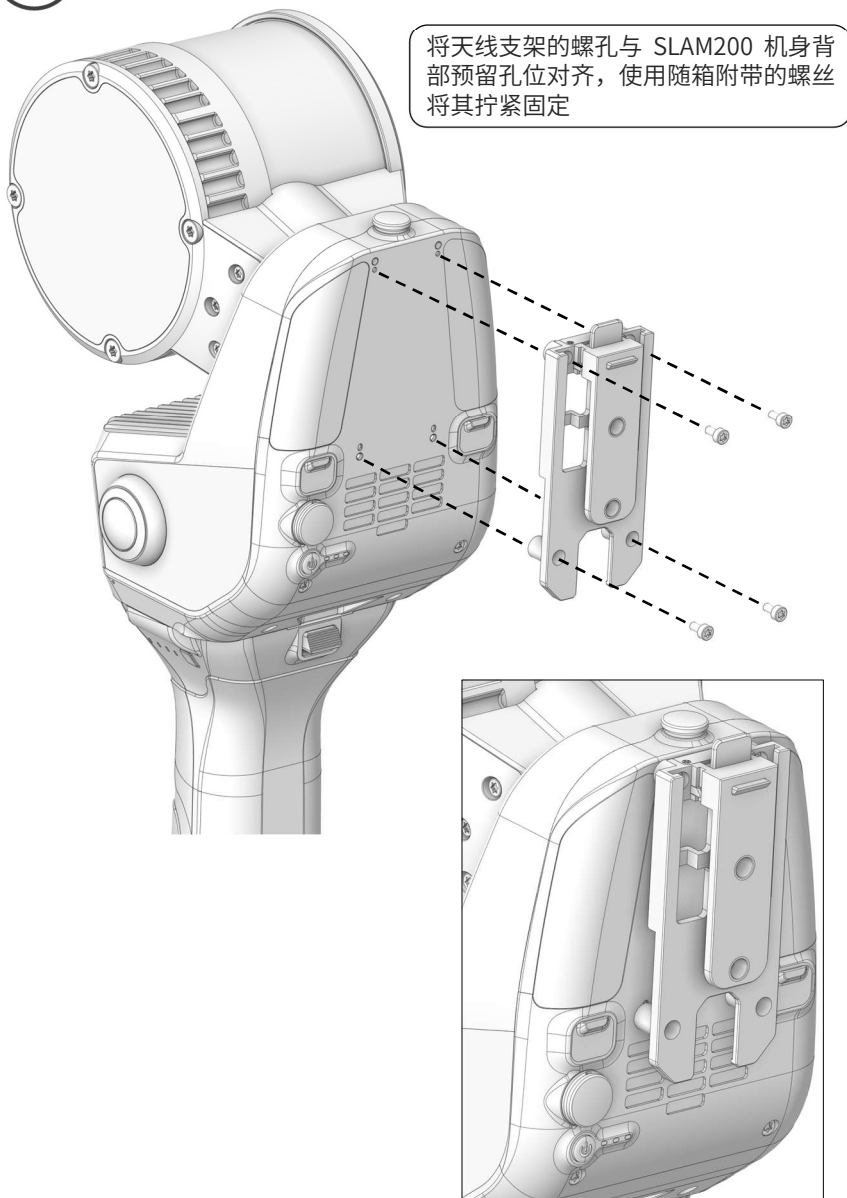

天线组件有防反插设计，反向无法插入，安装前需先确认天线方向与支架插槽位置匹配，再将天线由上至下插入，听到“咔哒”声后，检查天线组件与支架贴合紧密且安装牢固。

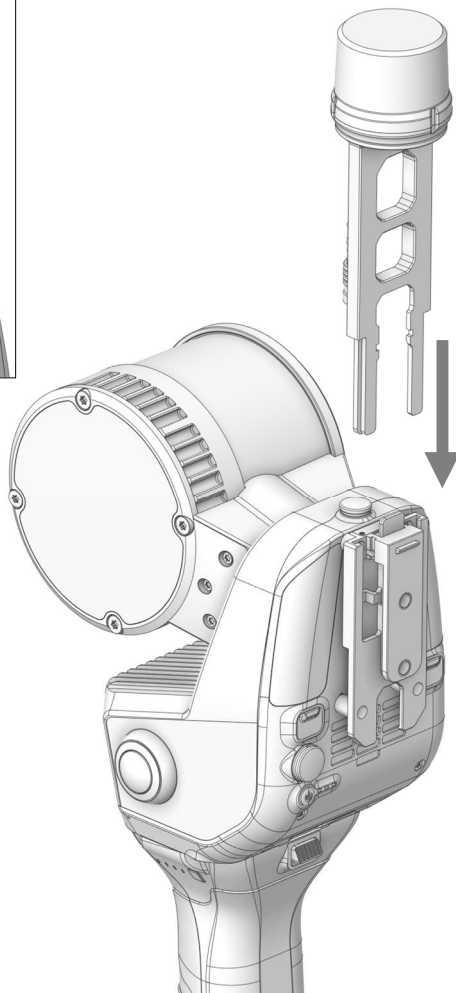
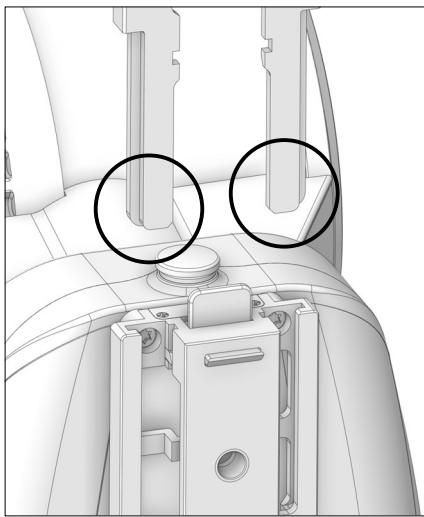

连接天线馈线（当不使用 RTK 功能时，可不安装该组件）

取下 SLAM200 机身上方的航插端口防尘帽，注意航插线端口有防反插设计及红色标识，反向无法插入，插入时注意航插线端口红点标记与设备航插端口红点标记对齐后再插入

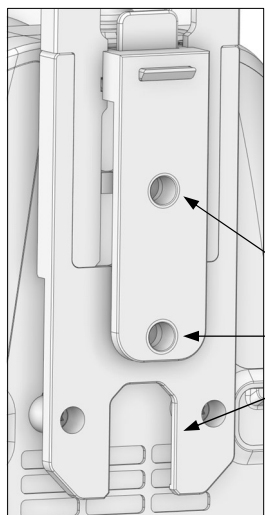
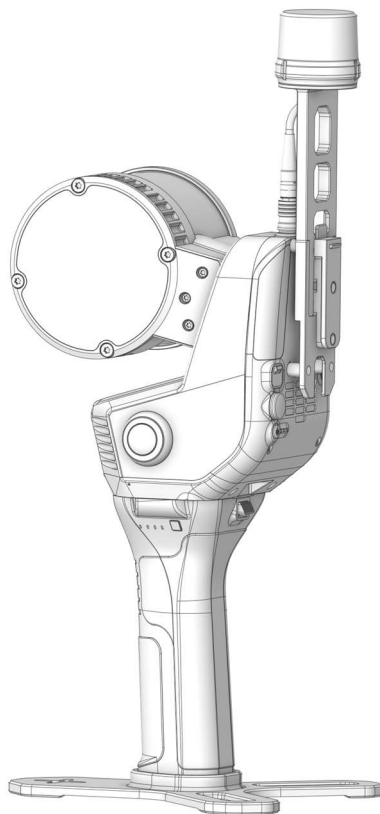
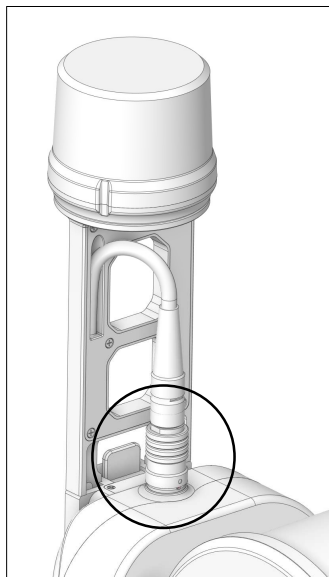

天线支架背部预留了两个 1/4 英寸安装孔位（英制 UNC 螺纹）和一个多功能扩展槽，支持大多数外挂手机支架安装

※ 手机支架需用户自行购买

设备回收

- ① 取出天线前，需先将航插线及设备分离，操作时用手捏住航插线的金属插头位置向上提即可顺利拔出，注意此插头有防脱设计，若直接拉拽航插缆则无法顺利将插头拔出
- ② 需要取出天线时，请按住天线支架上的“释放按钮”再向上取出天线组件

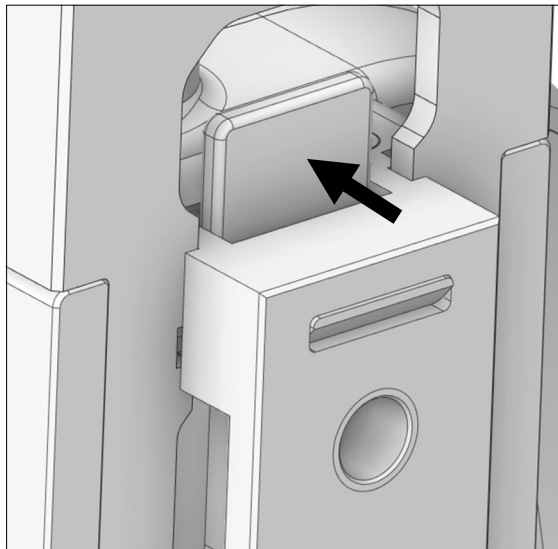
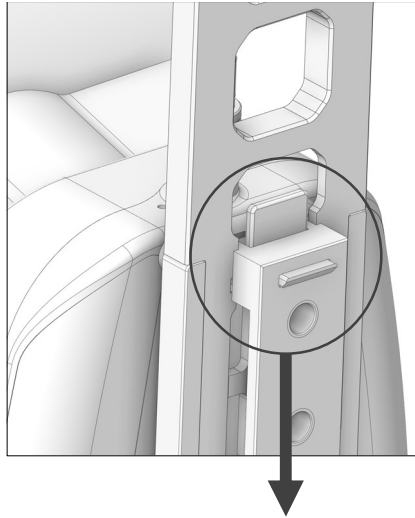
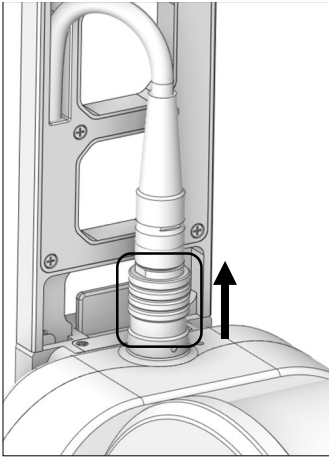

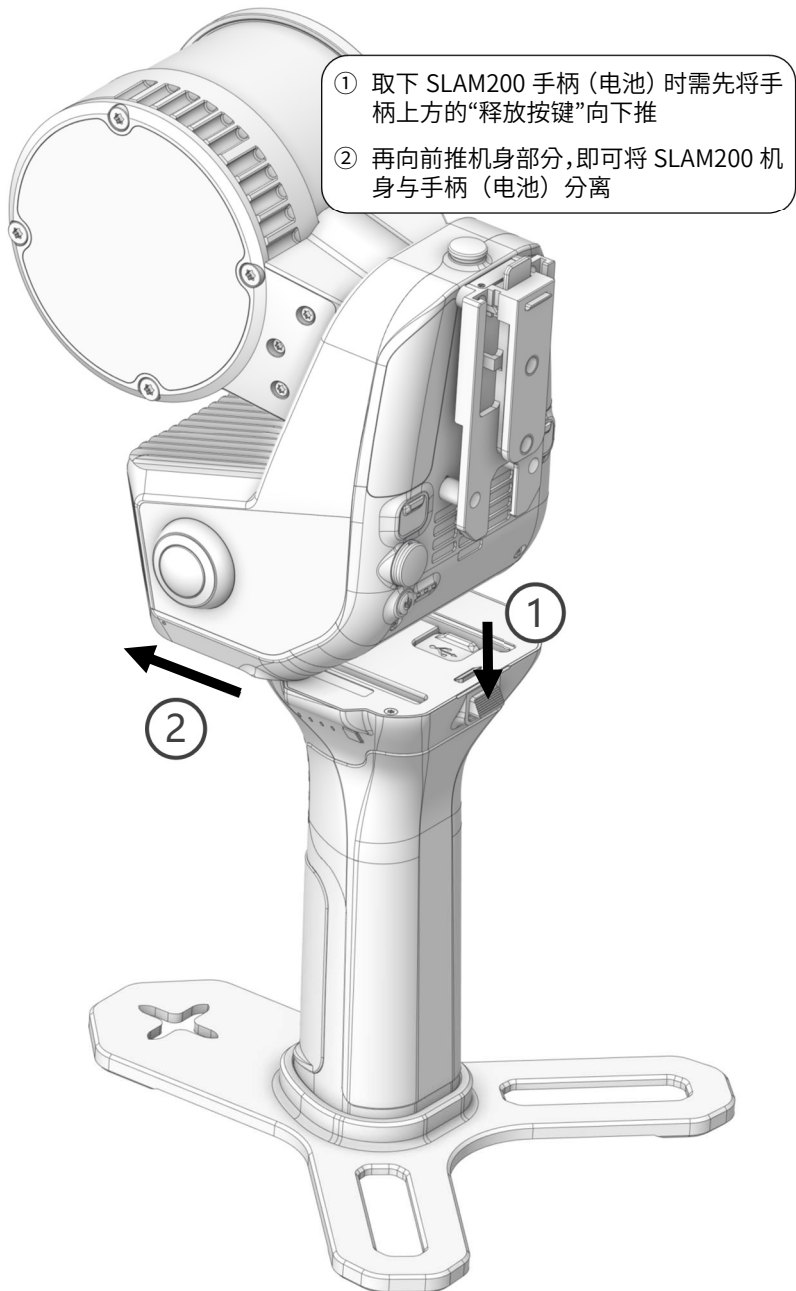

指示灯说明

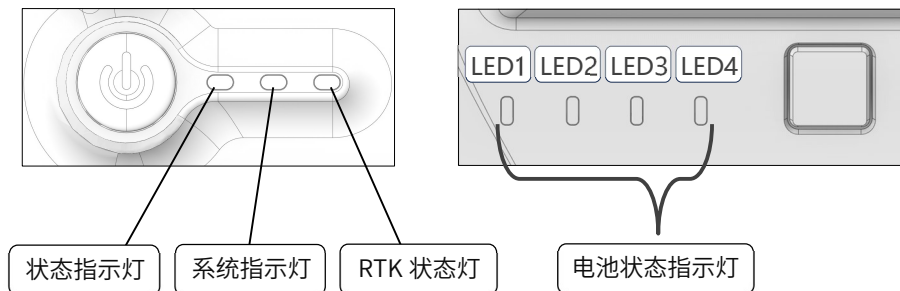

LED	显示	说明	
状态灯	白灯快闪	MCU固件升级中	
	红灯常亮	设备正在初始化, 未准备好	
	绿灯常亮	设备准备完成	
	绿灯闪	正在采集数据	
	绿灯快闪	停止采集, 正在保存数据	
	蓝灯闪烁至熄灭	关机	
系统灯	白灯常亮	系统固件升级中	
	红灯闪	系统未准备好	
	蓝灯常亮	系统准备完成	
RTK状态灯	红灯快闪	无网络	
	红灯慢闪	有网络	无定位
	红灯常亮		单点定位
	蓝灯常亮		伪距定位
	绿灯慢闪		浮点定位
	绿灯常亮		固定定位

蜂鸣器	状态	提示音
	开机	嘀一声
	关机	嘀一声
	低电量	每10秒 嘀一声
	超低电量	每1秒 嘀一声
	Mark点信息采集	点信息采集成功 嘀一声
	开始采集	嘀一声
	停止采集	嘀一声
	开始工作1分钟开始建图时	嘀一声
	结束工作，数据存储完成	嘀一声

SLAM200 电池 LED 指示灯状态表					
状态		LED1	LED2	LED3	LED4
电量指示	0%~12%	慢闪(1Hz)	灭	灭	灭
	13%~24%	常亮	灭	灭	灭
	25%~37%	常亮	慢闪(1Hz)	灭	灭
	38%~49%	常亮	常亮	灭	灭
	50%~62%	常亮	常亮	慢闪(1Hz)	灭
	63%~74%	常亮	常亮	常亮	灭
	75%~87%	常亮	常亮	常亮	慢闪(1Hz)
	88%~100%	常亮	常亮	常亮	常亮

说明：按键查询电量时 LED 灯会点亮 6 秒，前 3 秒显示电量，后三秒如果电池正常就显示电量，否则显示保护状态。更详细灯语说明请参考《SLAM200 产品手册》

电池充电



对 SLAM200 电池手柄进行充电，
约 2 小时充满（0%至 100%）。

输入：交流 100 V -240V ~50/60 Hz

输出：支持 PD3.0 协议 20V 3A

方式一：将充电器连接至 SLAM200 智能电池手柄的 Type-C3 接口进行充电。

方式二：当智能电池手柄已安装至 SLAM200 机身时，将充电器连接至机身的 Type-C1 接口进行充电。

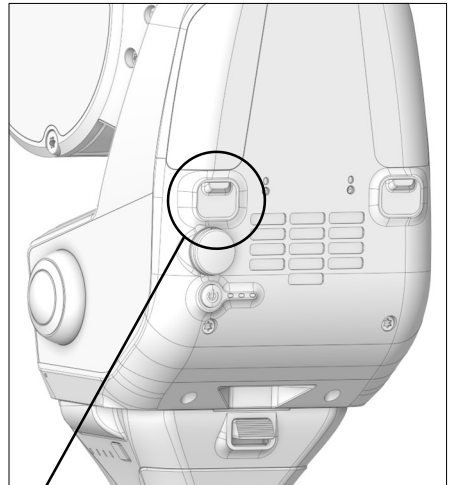

电池充电口

数据存储

- SLAM200 采用内置 SSD 存储器，容量 512GB，通过数据线连接 PC 进行数据交互；
- SLAM200 SSD 接口（Type-C2）支持开机/关机状态下都可读取数据；
- 建议 SSD 磁盘至少保留 5%以上的容量，避免因数据过多而导致磁盘读写速度降低以及容量不足问题；
- 删除数据时建议使用格式化的方式(可以快速格式化)，这样能够使 SSD 磁盘获取更好的存储速度。

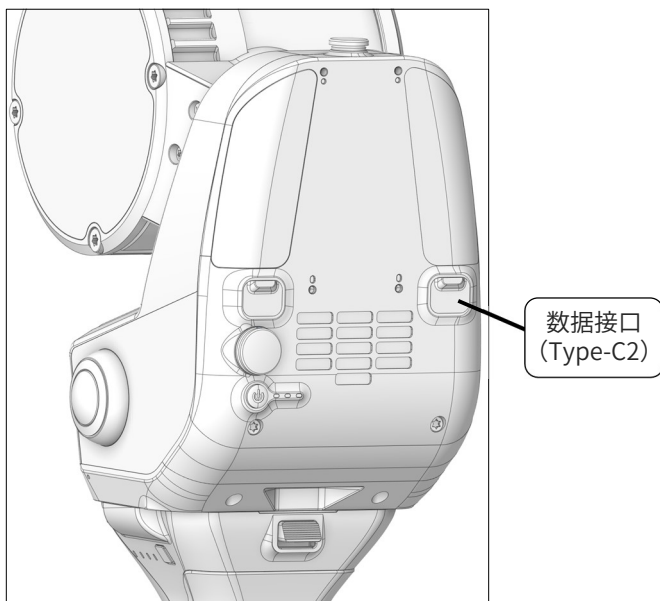

产品激活

扫描仪在使用前需注册飞马账号并进行设备激活，具体软件获取地址及注册、激活流程详见《SLAM200 产品手册》“SLAM GO”部分。

外业数据采集

设备开机

长按扫描仪开关键 3 秒，设备上电后激光头开始旋转自检，请等待。。。。

- 系统指示灯【蓝灯常亮】；
- 状态指示灯【绿灯常亮】；
- 激光头停止转动；

此时设备启动成功，为待机状态。

注意！

- 设备开机时请平稳握持扫描仪，并保持激光头竖直向上；
- 设备自检完成后不要用手转动激光器；
- 可将扫描仪置于安全稳固的桌面或平整的地面上。

开始采集

扫描仪开始数据采集前需要先进行静置校准，摆放位置要求距离被测物体距离 >0.4 米且不宜过远，静置阶段至少需要 60 秒再开始运动采集，静置时不可将扫描仪拿在手上，必须平稳的放置于安全的地面或者桌面等固定表面，短按扫描仪开关键，状态指示灯先会改为【绿色快闪】，此时设备正在进行校准，时长为 60 秒（手机 APP 会显示读秒倒计时），60 秒后状态指示灯改为【绿色慢闪】，并开始数据采集。静置时如放置位置略有倾角但可保证扫描仪静置不动也同样符合静置要求。

提示：

- 数据采集过程中请保持扫描仪处于身体前方，与行走方向一致，请保持设备直立；
- 设备在上电开机后和数据获取过程中机身可能会发热，并伴有散热风扇转动的声音属于正常现象。

控制点采集

当需要采集控制点时，请先将设备底座的十字中心对准控制点，此时短按控制点采集键，听到“嘀”一声后控制点采集成功，采集控制点时无需等待，采集完当前点信息后可继续进行之后的数据采集。

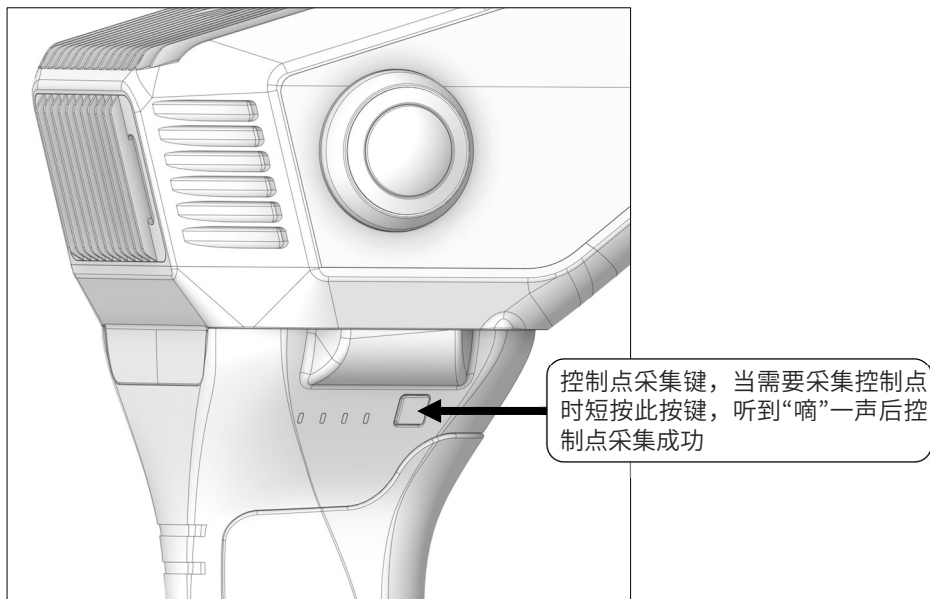
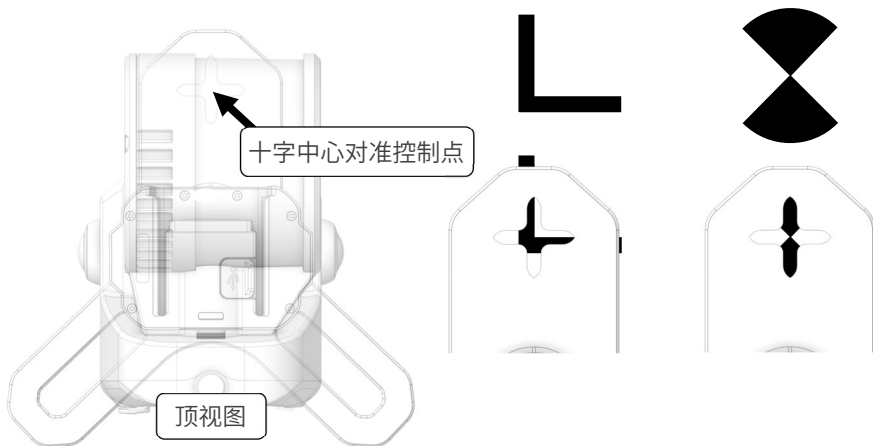

停止采集

短按扫描仪开关键，结束数据采集，状态指示灯恢复【绿灯常亮】待机状态；如需获取设备“实时建图”成果，请在设备关机或下一次采集前，等待设备完成本次的“实时建图”，等待时间约为本次采集时间的 1/10。

例：本次采集时间为 10 分钟，停止采集后需等待 1 分钟时长。

设备关机

长按扫描仪开关键可关闭设备，待系统指示灯与状态指示灯全部熄灭，此时设备关闭。

注意！

- 在系统指示灯与状态指示灯全部熄灭前请不要将智能电池手柄移除。

数据检查

数据采集完毕后可将扫描仪关闭，使用数据线连接 SLAM200 与 PC，找到以“SN_XXXX”命名的文件夹并将其拷贝至备份目录；每次数据采集完成后系统都将自动生成此文件夹，根据文件夹名称尾号数字大小可识别数据采集先后顺序。

问题分析

当采集的数据出现问题时，请将扫描仪存储卡内以“LOG”命名的文件夹打包压缩后提交给飞马售后部门进行分析。



了解更多产品详细信息，请通过以下网址访问【起司行业知识库】

<http://knowledge.cheesi.cn/>

如果您对说明书有任何疑问或建议，请通过电子邮箱联系我们：

aftersales@feimarobotics.com

(English)

Notice

This article is the SLAM200 Quick Start Guide. For more details about this device, please refer to the SLAM200 Product Manual.

Tips : —Important content of special reminders.

Notice! — Important elements that may cause damage to the equipment if operated incorrectly.

 Warning — Important content. The wrong operation may cause equipment damage or even personal injury.

Warning

- Operators should always pay attention to the surrounding environment when collecting data to avoid safety accidents caused by distractions.
- SLAM200 does not have explosion-proof attributes, and is strictly prohibited to be used near gas stations or in dangerous scenes such as mines, pits, septic tanks, etc. where gas, natural gas, methane, and other flammable and explosive gases gather.
- To avoid fire, property damage and personal injury, use the battery, charging and storage process must follow the guidelines in this manual.

Notice !

- The SLAM200 is a high-precision control device. Dropping or any impact may cause damage to the SLAM200, resulting in malfunction.
- After transferring data from the SLAM200 to a computer, please “Safely Remove Hardware” before disconnecting the USB cable.
- To power off the SLAM200 device, please use the power button. Do not remove the battery handle or disconnect the power source (such as USB-PD) while the device is powered on.

- During use of the SLAM200, please ensure protection against dust and sand.
- When using the SLAM200, protect the laser and camera lens from scratches caused by hard objects.
- The splash-proof, water-resistant, and dustproof features are not permanently effective. Protective performance may decrease with normal wear, and liquid damage is not covered under warranty.
- To prevent liquid damage, please avoid the following actions:
 - ① Placing the SLAM200 in high-pressure or high-flow water, or intentionally submerging it in water.
 - ② Dropping the SLAM200 onto the ground or subjecting it to other impacts.
 - ③ Disassembling the SLAM200, including unscrewing any screws.

Product Overview

The SLAM200 is the third-generation high-precision handheld 3D Laser scanner meticulously developed by Feima Robotics. This scanner integrates a high-performance 32-line laser sensor, two 12-megapixel panoramic cameras, a built-in high-precision GNSS module, and an enhanced processing unit, delivering a groundbreaking experience in spatial data acquisition for users.

The SLAM200 is equipped with the SLAM GO APP and SLAM GO POST Pro post-processing software. Its proprietary SLAM mapping algorithm and coloring algorithm have undergone major upgrades, enabling real-time color point cloud generation. This upgrade significantly improves mapping accuracy and operational efficiency, allowing users to effortlessly obtain high-density, ultra-detailed, and richly colored 3D point cloud results.

As an upgraded successor to the previous two generations, the SLAM200 not only inherits the excellent performance of its predecessors but also achieves a qualitative leap in accuracy, detail capture, colorization, and operational convenience. With its exceptional performance and innovative design, the SLAM200 sets a new benchmark in the surveying field, leading the future development of spatial data acquisition technology.

Part Introduction

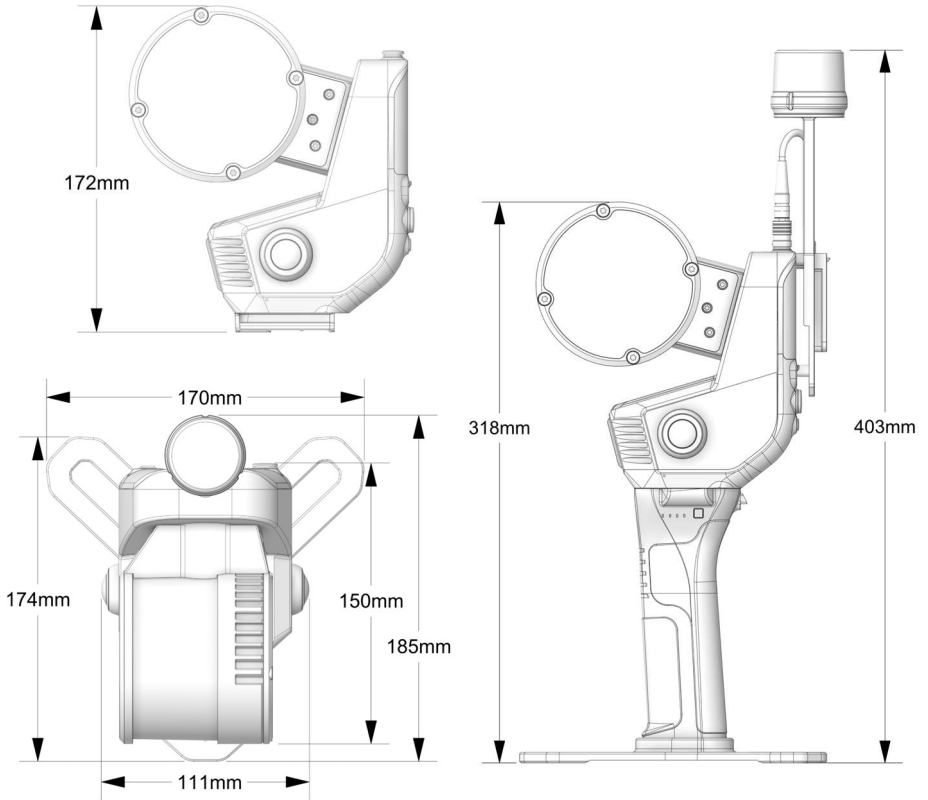

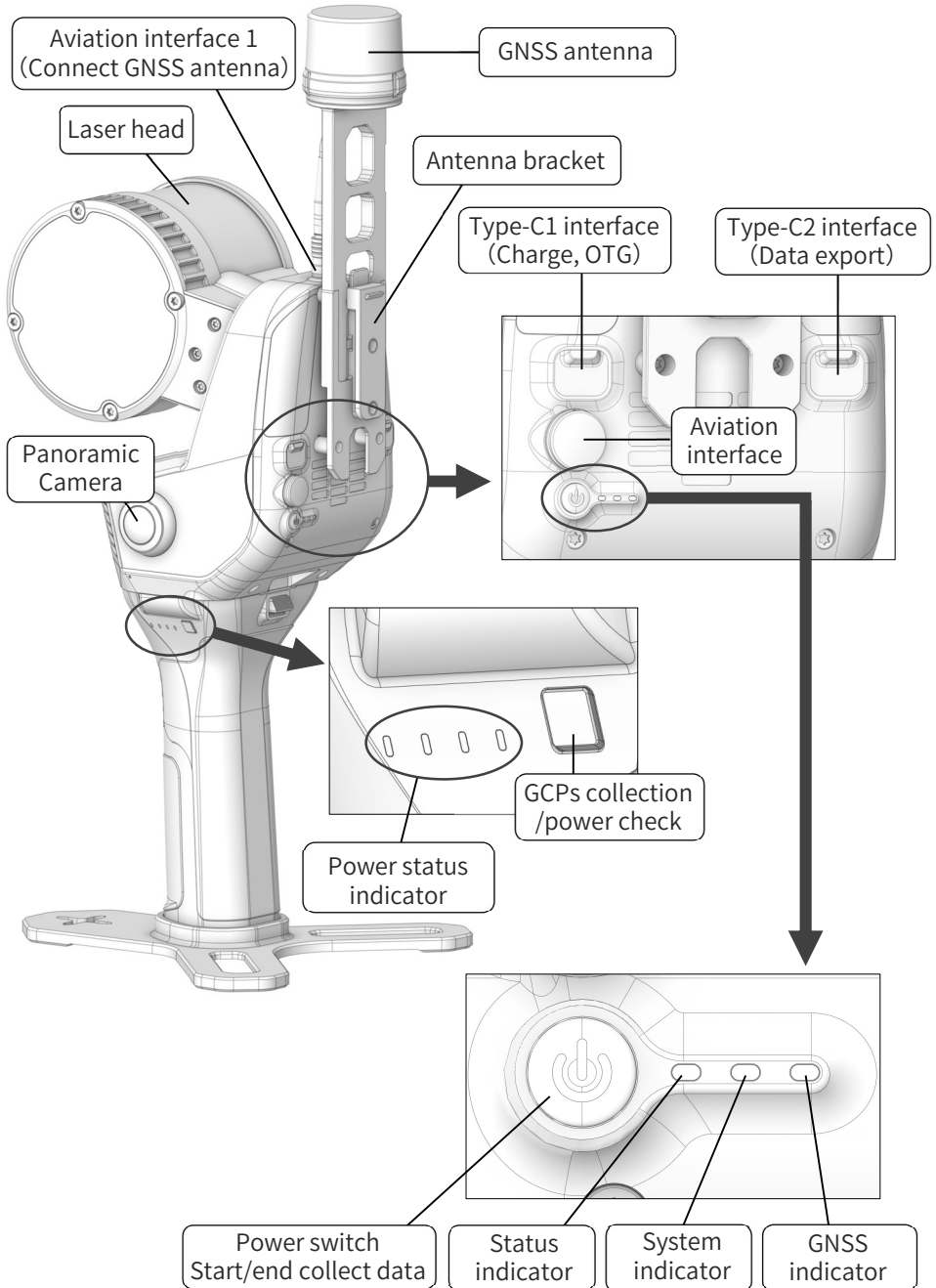

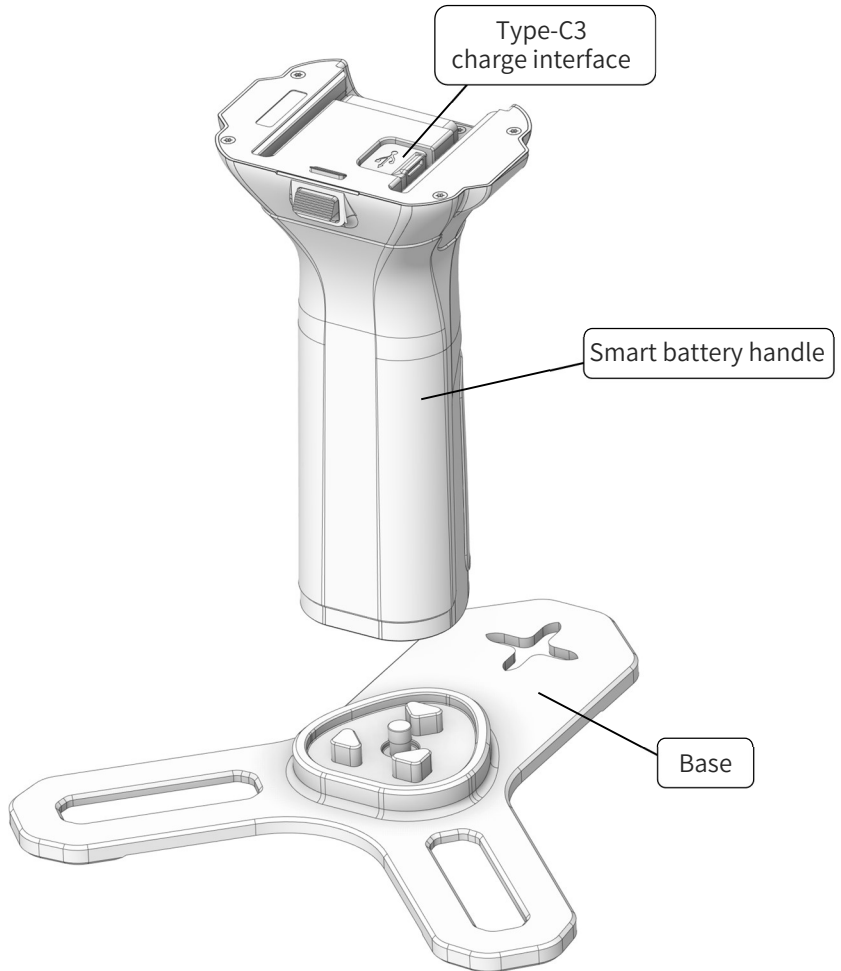

SLAM200 Operating Process

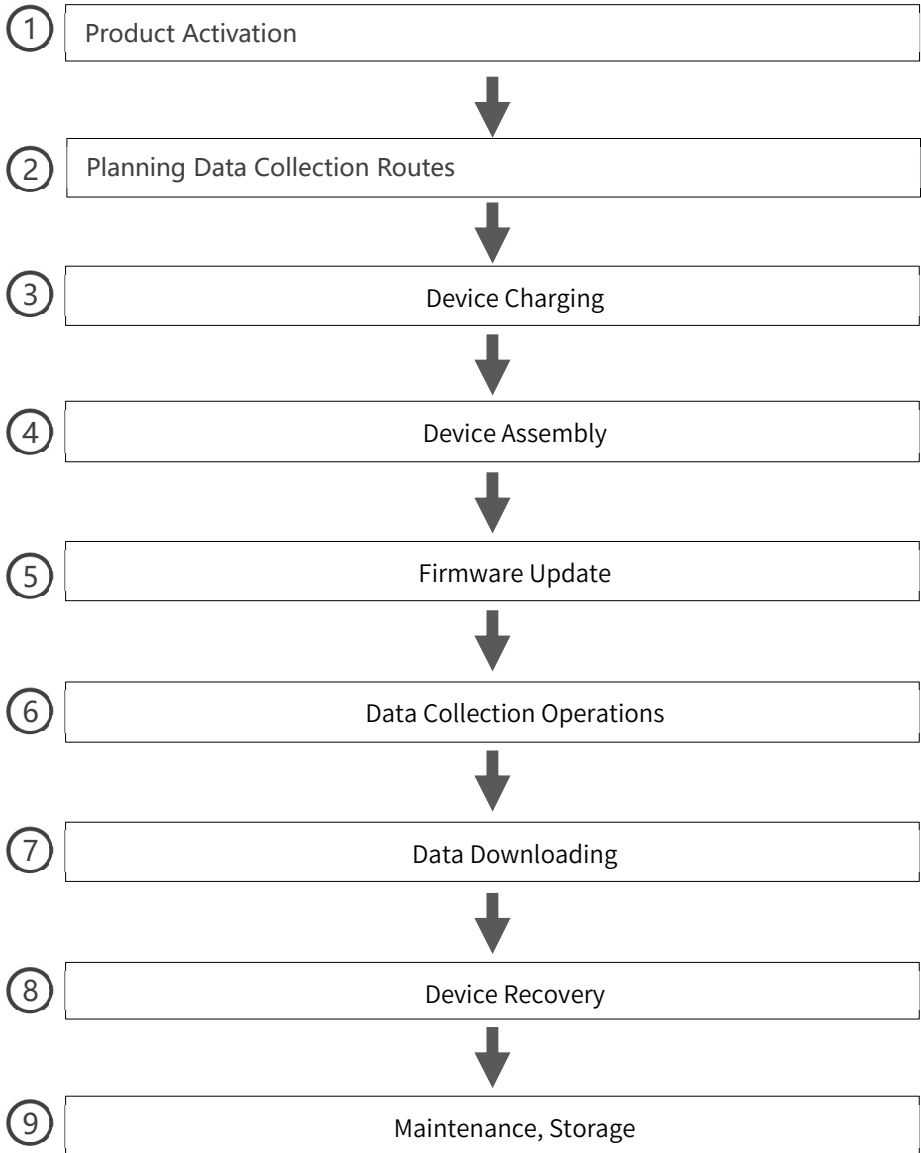

Device Assembly

1

Mounting Base

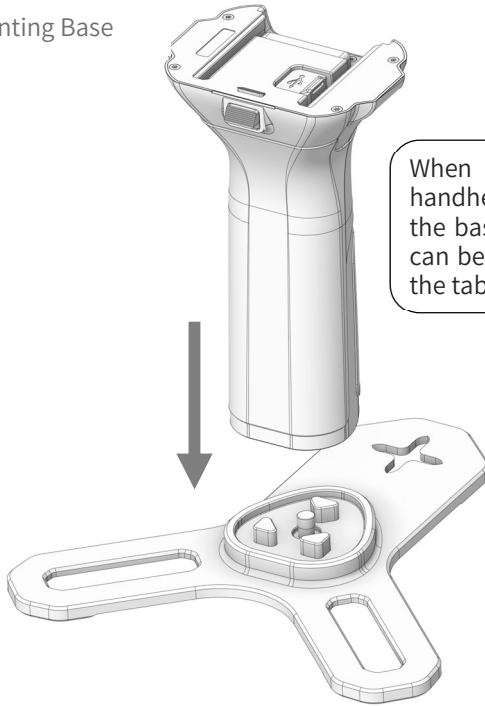

When using the device handheld, please install the base first, so that it can be safely placed on the table or floor

Bottom view

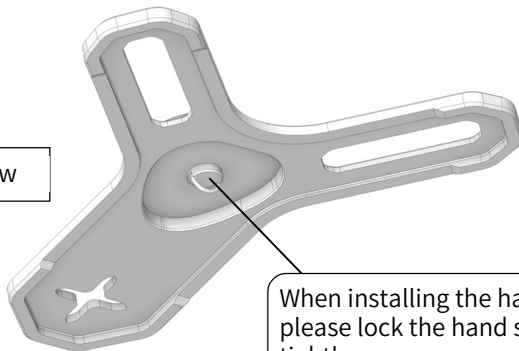

When installing the handle please lock the hand screw tightly

2 Assemble Handle

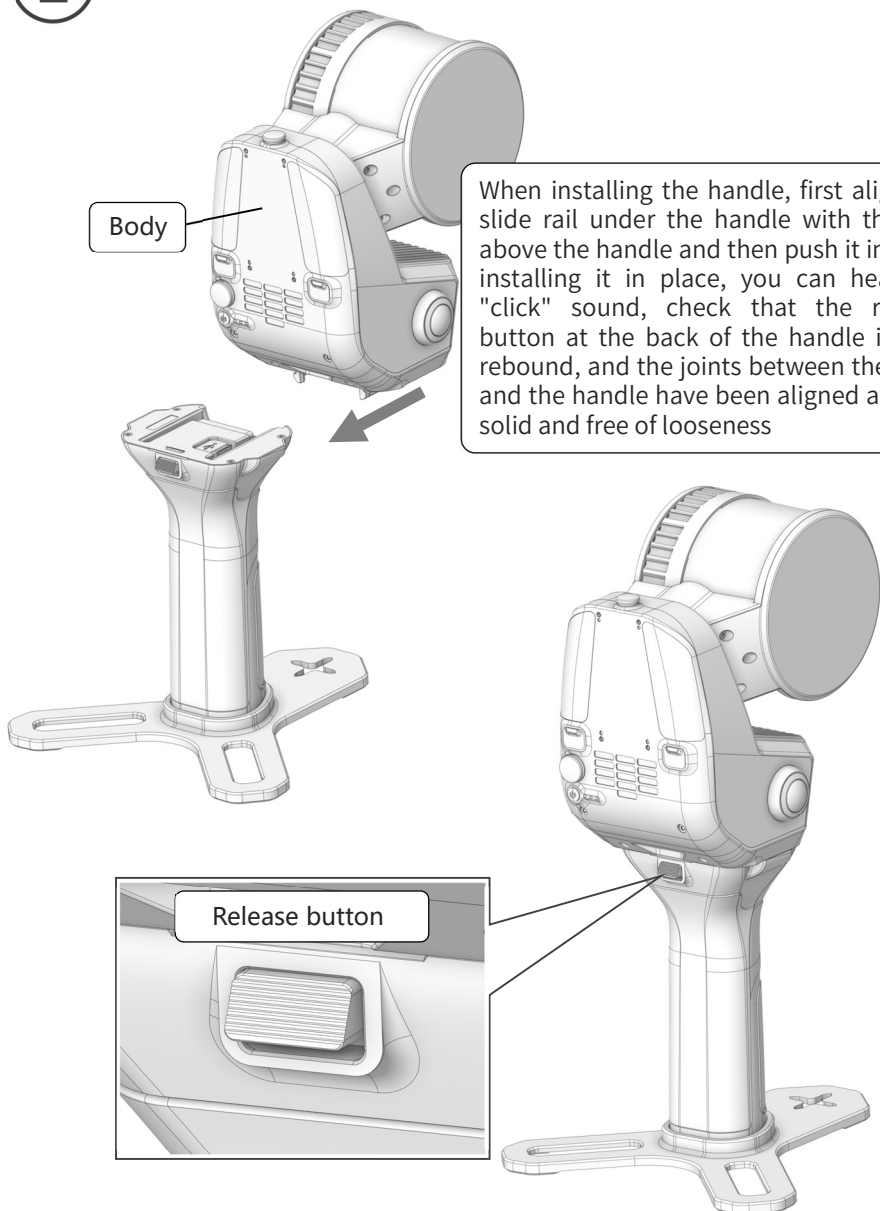

3 GNSS Antenna

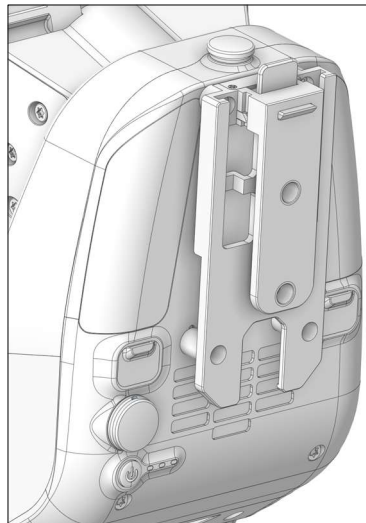
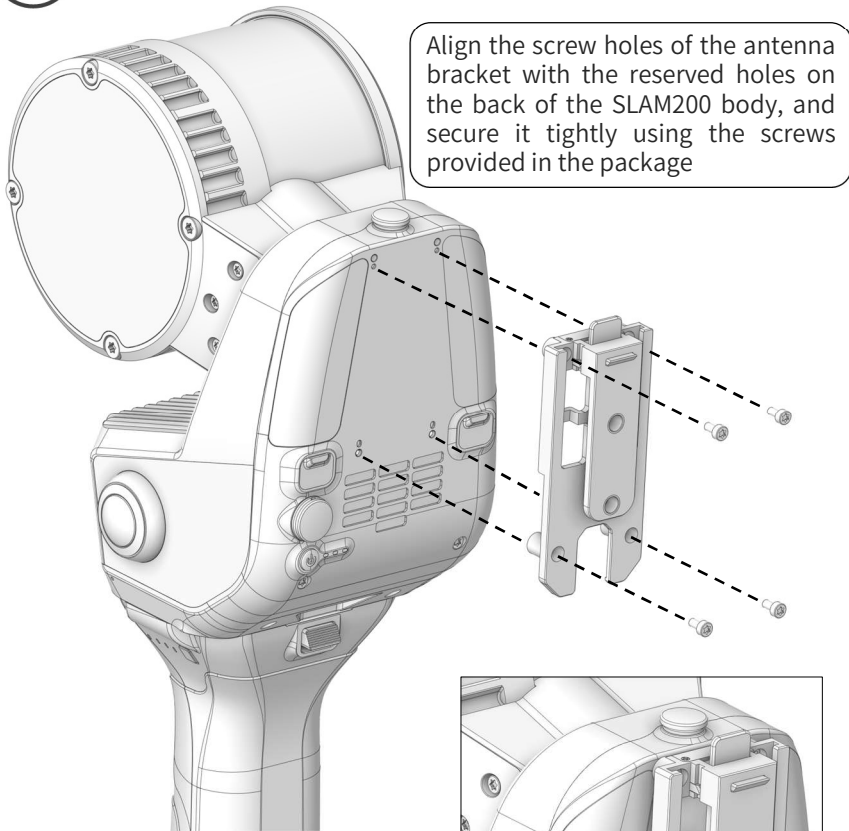

The antenna assembly has a reverse-insertion prevention design and cannot be inserted incorrectly. Before installation, confirm that the antenna direction aligns with the bracket slot. Then insert the antenna from top to bottom. After hearing a “click,” check that the antenna assembly fits snugly with the bracket and is securely installed

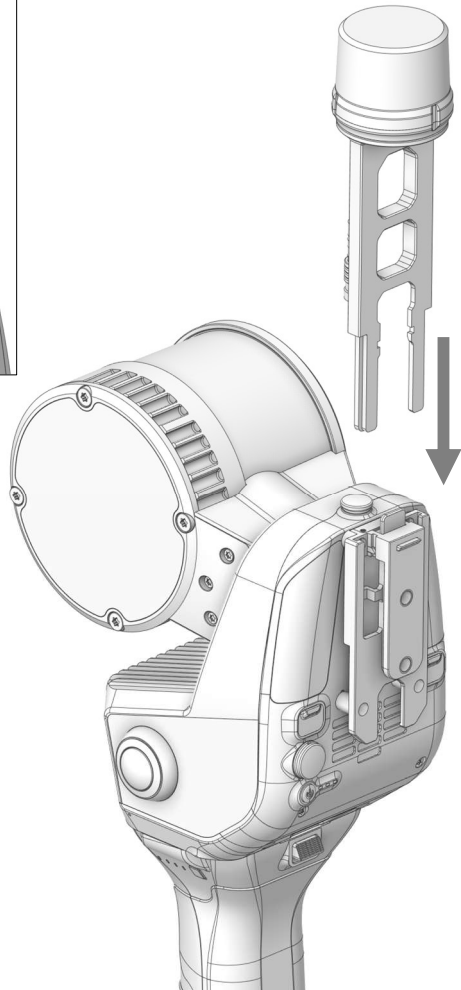
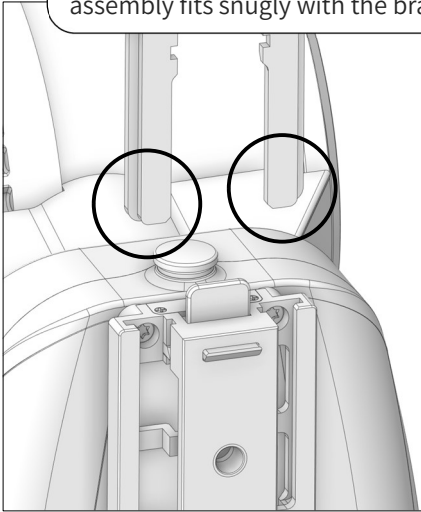

Connect the antenna feeder cable (this component may be omitted if the RTK function is not used)

Remove the dust cap from the aviation plug port on the top of the SLAM200 body. Note that the aviation plug has a reverse-insertion prevention design and a red marking, which prevents incorrect insertion. When connecting, align the red dot on the aviation plug with the red dot on the device's aviation port before inserting

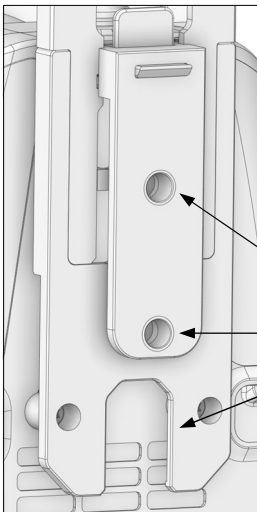
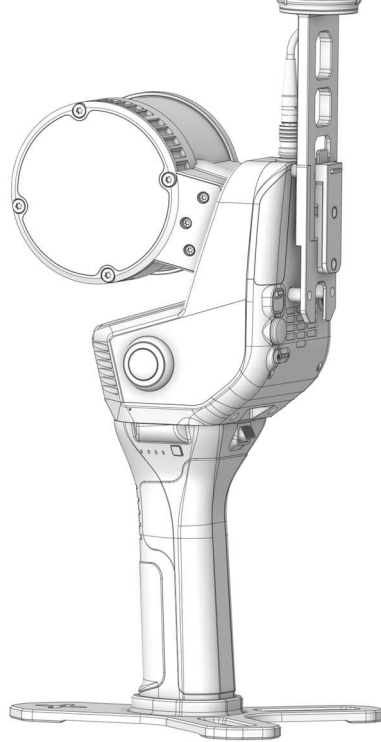
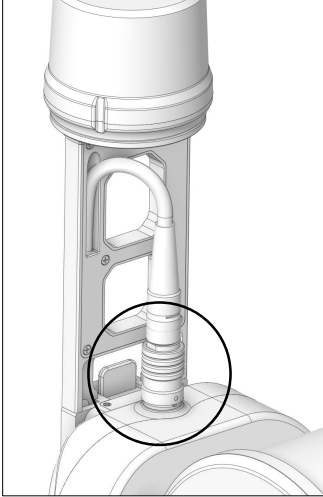

The back of the antenna bracket has two reserved 1/4-inch mounting holes (imperial UNC thread) and a multifunctional expansion slot, supporting the installation of most external phone holders

※ The phone holder needs to be purchased separately by the user

Equipment Recovery

- ① Before removing the antenna, disconnect the aviation plug cable from the device. Hold the metal head of the aviation plug and lift it upward to remove it smoothly. Note that this plug has an anti-disconnection design, so pulling directly on the cable will not allow the plug to be removed
- ② To remove the antenna, press the "release button" on the antenna bracket and then lift the antenna assembly upward

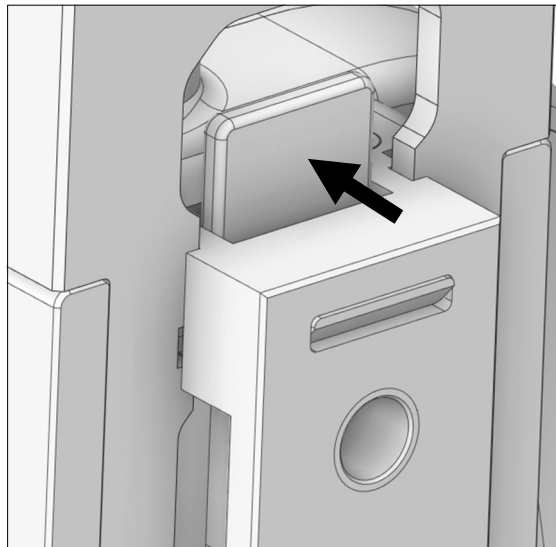
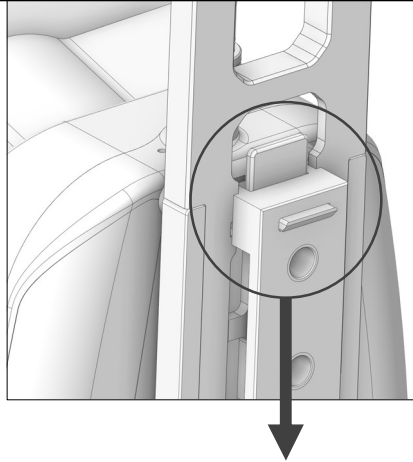
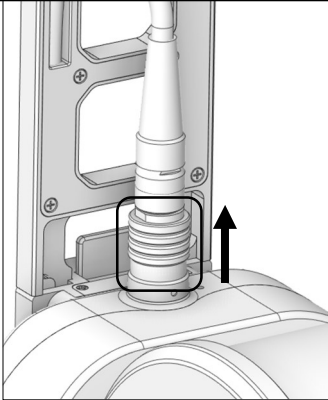

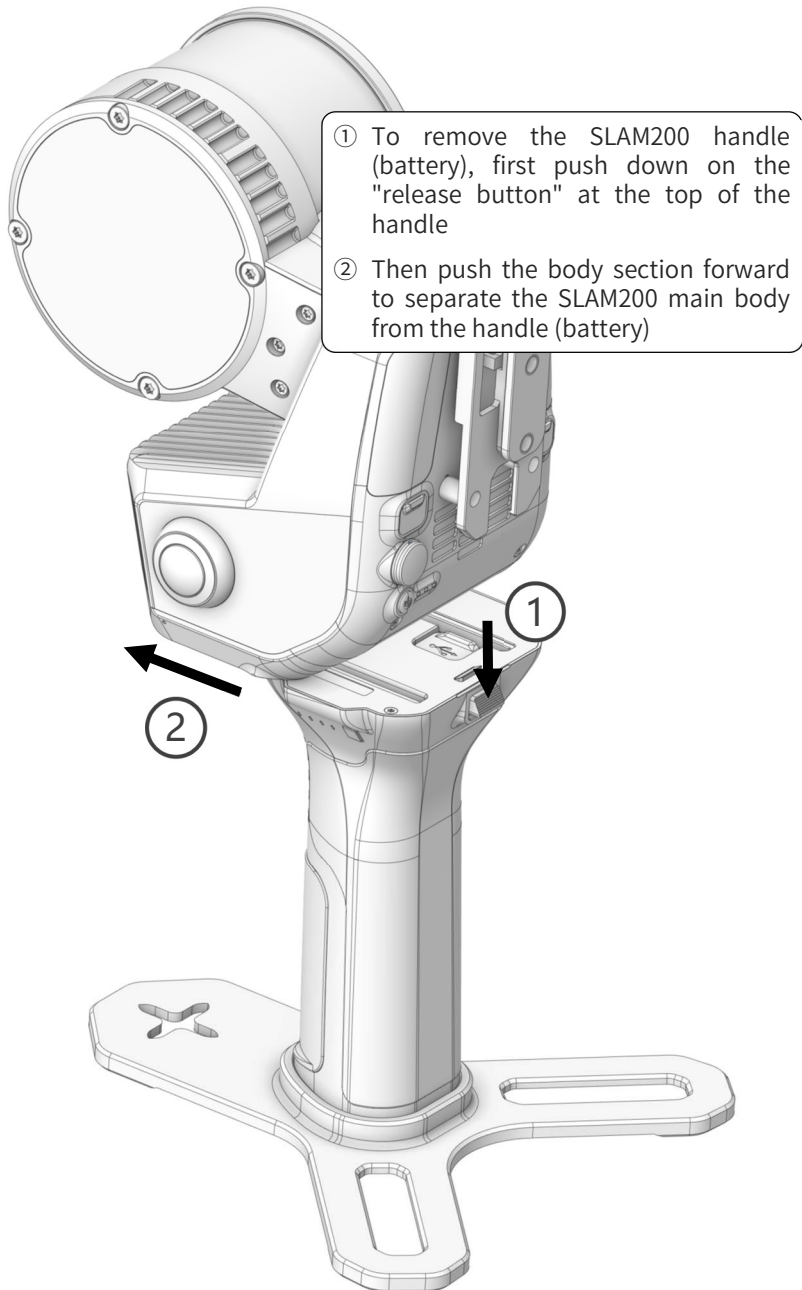

Indicator Introduction

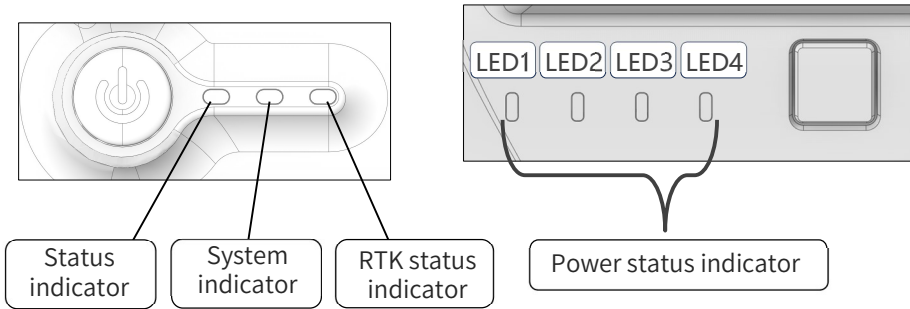

LED	Display	Introduction	
Status Indicator	White Light Fast Flashing	MCU Firmware Upgrading	
	Red Light On	Device Initializing and Not Ready	
	Green Light On	Device Ready	
	Green Light Flashing	Data Collecting	
	Green Light Fast Flashing	Stop Collection, Saving Data	
	Blue Light Flashing to End	Power Off	
System Indicator	White Light On	System Firmware Upgrade in Progress	
	Red Light Flashing	System Not Ready	
	Blue Light Always On	System Ready	
RTK Indicator Light	Red Light Fast Flashing	No Internet	
	Red Light Slow Flashing	Internet	No Location
	Red Light On		Single Point Solution
	Blue Light On		Pseudo-distance Solution
	Green Light Slow Flashing		Float Solution
	Green Light On		Fixed Solution

Buzzer	Status	Prompt Tone
	Power on	Beep
	Power Off	Beep
	Low Battery	Beep every 10 seconds
	Ultra-low Battery	Beep every second
	Mark Point Information Collection	Click Information Collection Success
	Start Collection	Beep
	Stop Collection	Beep
	Start Work 1 Minute to Start Mapping	Beep
	Data Storage Complete	Beep

SALM200 Battery LED Indicator Status List					
	Status	LED1	LED2	LED3	LED4
Power Indicator	0%~12%	Slow Flash(1Hz)	Out	Out	Out
	13%~24%	Always On	Out	Out	Out
	25%~37%	Always On	Slow Flash(1Hz)	Out	Out
	38%~49%	Always On	Always On	Out	Out
	50%~62%	Always On	Always On	Slow Flash(1Hz)	Out
	63%~74%	Always On	Always On	Always On	Out
	75%~87%	Always On	Always On	Always On	Slow Flash(1Hz)
	88%~100%	Always On	Always On	Always On	Always On

Description:

The LED will light up for 6 seconds when you press the key to check the power level, the first 3 seconds will show the power level, the last 3 seconds will show the power level if the battery is normal, otherwise it will show the protection. For more detailed lamp instructions, please refer to the SLAM200 Product Manual.

Battery Charging



Charge the SLAM200 battery handle, about 2 hours to full (0% to 100%)

Input: AC 100 V to 240V to 50/60 Hz

Output: Support PD3.0 Protocol 20V 3A

Method 1: Connect the charger to the Type-C2 port of the SLAM200 smart battery handle for charging.

Method 2: When the smart battery handle is installed on the SLAM200 body, connect the charger to the Type-C1 port on the body for charging.

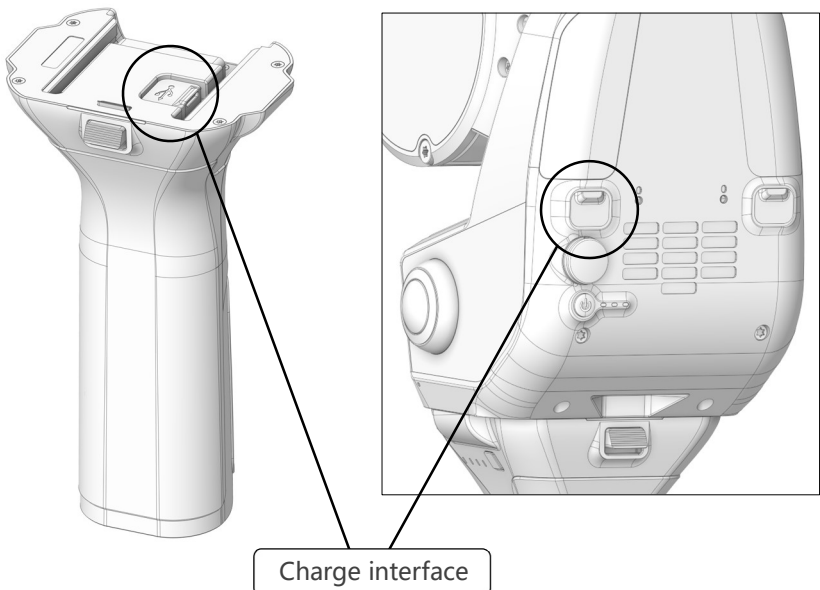

Data Storage

- The SLAM200 uses an internal SSD with a capacity of 512GB, and data can be transferred via a data cable connected to a PC.
- The SLAM200 SSD interface (Type-C2) supports data reading in both powered-on and powered-off states.
- It is recommended to keep at least 5% of the SSD disk space free to avoid slow read/write speeds and insufficient capacity due to excessive data.
- When deleting data, it is recommended to use formatting (quick format is acceptable) to optimize the SSD disk's storage speed.

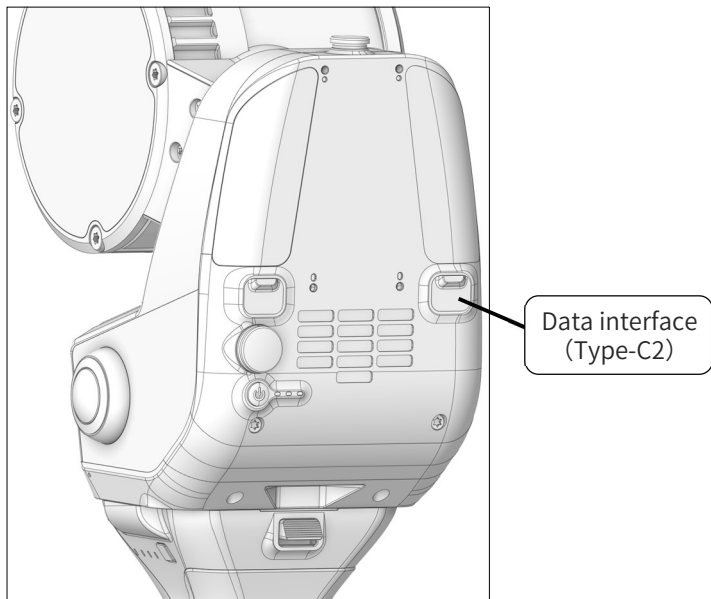

Device Activation

The scanner must be registered with a Feima account and activated before use. For specific software download addresses and the registration and activation process, please refer to the "SLAM GO" section in the *SLAM200 Product Manual*.

Data Collection

Device Power-On

Press and hold the scan button for 3 seconds to power on the device. After powering on, the device will perform a self-test. Please wait....

- The system indicator light will show a **steady blue light**.
- The status indicator light will show a **steady green light**.
- Laser head stops rotating.

At this point, the device has successfully started and is in standby mode.

Notice !

- When powering on the device, hold the scanner steadily and keep the laser head upright.
- Do not manually rotate the laser after the device self-check is complete.
- Place the scanner on a safe, stable table or a flat surface if needed.

Start Data Collection

Before starting data collection, the scanner needs to perform a calibration. The placement requirements are: the distance from the object being measured should be greater than 0.4 meters, but not too far. The calibration phase must last at least 60 seconds before motion-based data collection begins. During calibration, do not hold the scanner in your hand; it must be placed steadily on a safe surface like the floor or a table.

Press the scan button briefly, and the status indicator light will start flashing green rapidly. At this time, the device is performing calibration, which takes

60 seconds (the mobile app will show a countdown). After 60 seconds, the status indicator light will switch to flashing green slowly, and data collection will begin. If the scanner is placed at a slight angle but remains stationary, it still meets the calibration requirement.

Tips :

- During data collection, keep the scanner in front of your body and aligned with your walking direction. Please keep the device upright.
- After powering on and during data collection, the device may heat up, and the sound of the cooling fan may be heard. This is a normal phenomenon.

Control Point Collection

When collecting control points(GCPs), first align the cross center on the device base with the control point. Then, briefly press the control point collection button. After hearing a “beep” sound, the control point will be successfully collected. There is no need to wait during control point collection; once the current GCP information is collected, you can continue with the subsequent data collection.

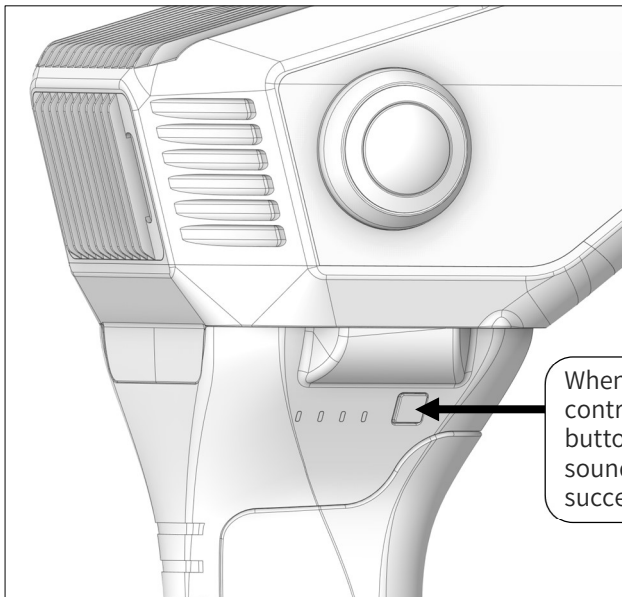
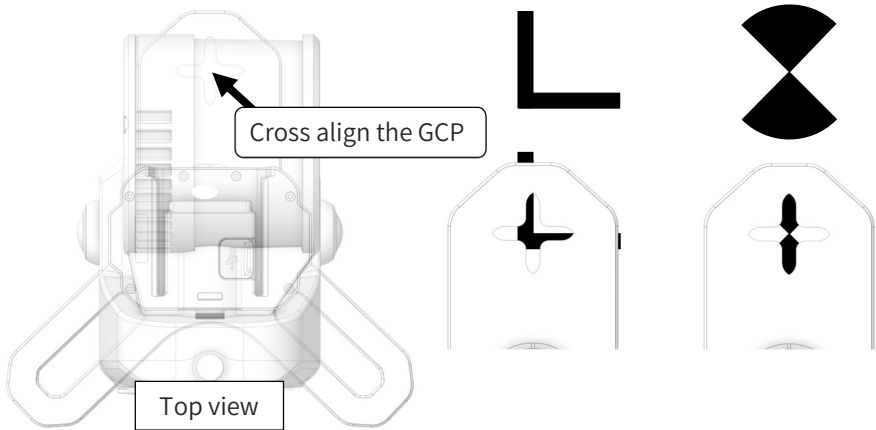

When you need to collect a control point, briefly press this button. After hearing a "beep" sound, the control point will be successfully collected

Stop Data Collection

Press the scanner power button briefly to end data collection; the status indicator will return to the standby state with a steady green light.

If you need to obtain the device's "real-time mapping" results, wait for the device to complete the "real-time mapping" process before powering off or starting the next collection. The wait time is approximately 1/10 of the collection duration.

For example, if the collection time was 10 minutes, wait for 1 minute after stopping the collection.

Power Off the Device

Press and hold the scan button to power off the device. Wait until both the system indicator and status indicator lights are completely off, at which point the device will be powered off.

Notice !

- Please do not remove the smart battery handle before both the system and status indicator lights are completely off.

Data Check

After data collection is completed, you can turn off the scanner and connect the SLAM200 to a PC using a data cable. Locate the folder named "SN_XXXXX" and copy it to a backup directory. After each data collection session, the system will automatically generate this folder. The numerical suffix at the end of the folder name helps identify the order in which the data was collected.

Problem Analysis

If there are issues with the collected data, please compress the folder named "LOG" in the scanner's storage card and submit it to the Feima after-sales department for analysis.

FCC Warning

This device complies with part 15 of the FCC Rules. Operation is subject to the following two conditions: (1) This device may not cause harmful interference, and (2) this device must accept any interference received, including interference that may cause undesired operation.

Any Changes or modifications not expressly approved by the party responsible for compliance could void the user's authority to operate the equipment.

Note: This equipment has been tested and found to comply with the limits for a Class B digital device, pursuant to part 15 of the FCC Rules. These limits are designed to provide reasonable protection against harmful interference in a residential installation. This equipment generates uses and can radiate radio frequency energy and, if not installed and used in accordance with the instructions, may cause harmful interference to radio communications. However, there is no guarantee that interference will not occur in a particular installation. If this equipment does cause harmful interference to radio or television reception, which can be determined by turning the equipment off and on, the user is encouraged to try to correct the interference by one or more of the following measures:

- Reorient or relocate the receiving antenna.
- Increase the separation between the equipment and receiver.
- Connect the equipment into an outlet on a circuit different from that to which the receiver is connected.
- Consult the dealer or an experienced radio/TV technician for help.

Specific Absorption Rate (SAR) information:

This product meets the government's requirements for exposure to radio waves. The guidelines are based on standards that were developed by independent scientific organizations through periodic and thorough evaluation of scientific studies. The standards include a substantial safety margin designed to assure the safety of all persons regardless of age or health.

FCC RF Exposure Information and Statement

The SAR limit of USA (FCC) is 1.6 W/kg averaged over one gram of tissue. Model: SLAM200 (FCC ID: 2A7JASLAM200) has also been tested against this SAR limit. This device was tested for typical body-worn operations 0mm from the body. To maintain compliance with FCC RF exposure requirements, use accessories that maintain a 0mm separation distance between the user's body.

Body-worn Operation

This device was tested for typical body-worn operations. To comply with RF exposure requirements, a minimum separation distance of 0mm must be maintained between the user's body, including the antenna. Third-party belt-clips, holsters, and similar accessories used by this device should not contain any metallic components. Body-worn accessories that do not meet these requirements may not comply with RF exposure requirements and should be avoided. Use only the supplied or an approved antenna.

Operation of this device in the band 5150-5250MHz is restricted to indoor use only.



For more detailed product information, please visit the following website:

<http://knowledge.cheesi.cn/>

If you have any questions or suggestions regarding the manual, please feel free to contact us via email at:

aftersales@feimarobotics.com.

www.feimarobotics.com